



The
Electrical
Power
Engineers

Qual-Tech Engineers, Inc.

201 Johnson Road – Building #1 · Suite 203
Houston, PA 15342-1300

Phone 724-873-9275 – Fax 724-873-8910
www.QualTechEng.com

ARC FLASH PPE GUIDELINES FOR INDUSTRIAL POWER SYSTEMS

For industrial applications in North America and many countries around the world, the key documents with regard to arc flash hazard protection are the following:

- NFPA 70E – Standard for Electrical Safety in the Workplace – 2009 Edition
- CSA Standard Z462-08 – Workplace Electrical Safety
- IEEE Standard 1584-2002 – IEEE Guide for Performing Arc-Flash Hazard Calculations

NFPA 70E and CSA Z462 define the following hazard/risk categories (or PPE levels) and the minimum cal/cm² rating for each:

- | | | | |
|-----------------|-------------------------|-----------------|------------------------|
| • PPE Level = 0 | 1.2 cal/cm ² | • PPE Level = 3 | 25 cal/cm ² |
| • PPE Level = 1 | 4 cal/cm ² | • PPE Level = 4 | 40 cal/cm ² |
| • PPE Level = 2 | 8 cal/cm ² | | |

The heat produced by the arc is a key factor in determining the appropriate PPE level. The heat is determined predominantly by the magnitude of the fault current and the duration of the fault, as well as how near the person is to the arc. When an arc occurs, the current is less than the maximum possible fault current due to the impedance of the arc. This is illustrated in Figure 1 as calculated in IEEE Standard 1584. The lower the system voltage, the more significant the arc impedance is in reducing the arcing fault current.

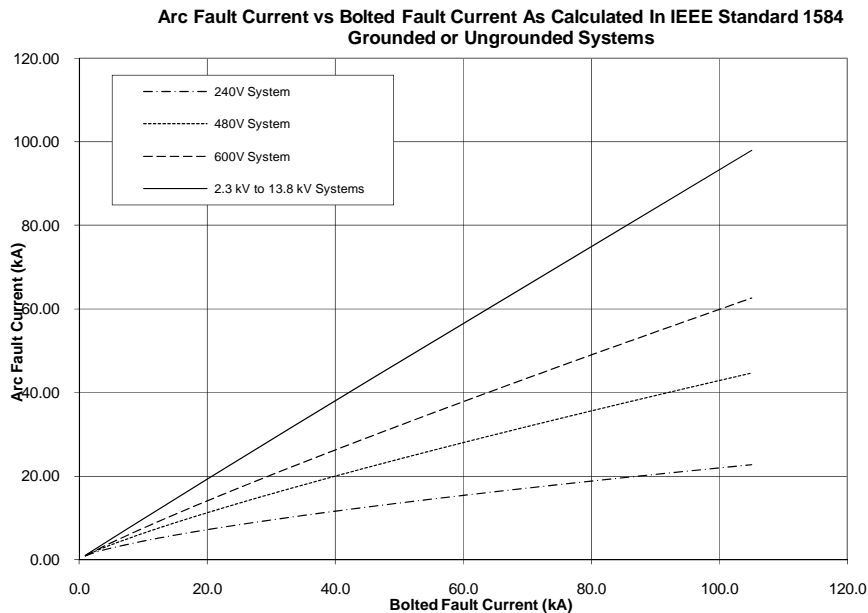

Figure 1

This document gives a practical overview of the personal protective equipment (PPE) levels that can be expected in an industrial plant. This analysis uses only the PPE levels of 0, 2, and 4, as is commonly done in many industrial facilities.

1.0 12.47 KV TO 13.8 KV SYSTEMS

Using the equations given in IEEE 1584, curves are given which define the maximum clearing time for a given bolted (or maximum) fault current that would correspond to a PPE level of 2 or 4 for 12.47 kV to 13.8 kV systems. A working distance of 36" is used. Figures 2 and 3 illustrate the calculated limits for metal enclosed switchgear for solidly grounded and impedance grounded systems respectively.

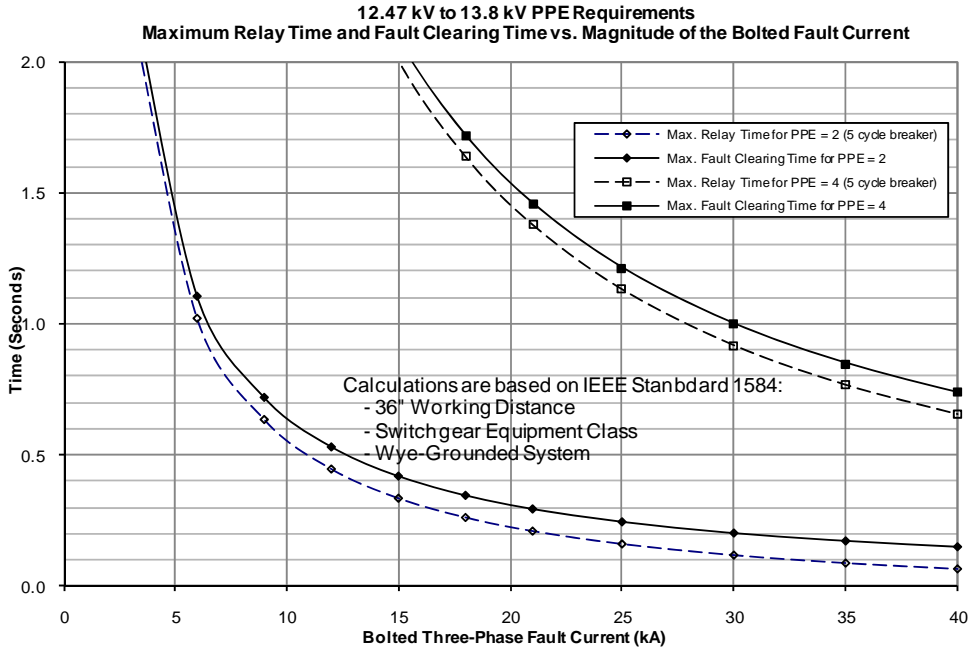

Figure 2

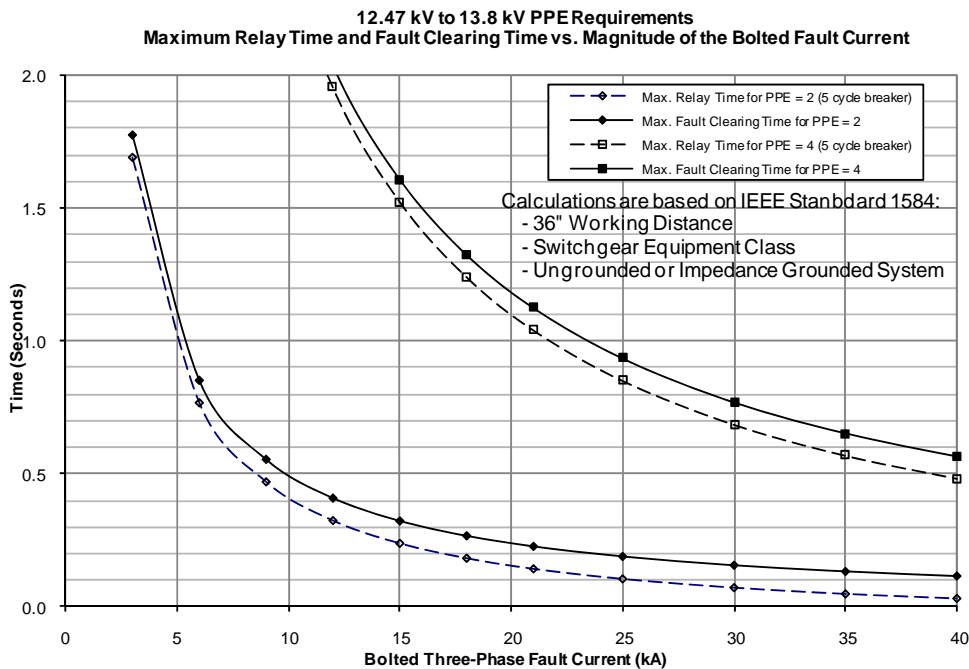

Figure 3

Figures 4 and 5 illustrate the calculated limits for open air switchgear for solidly grounded and impedance grounded systems respectively.

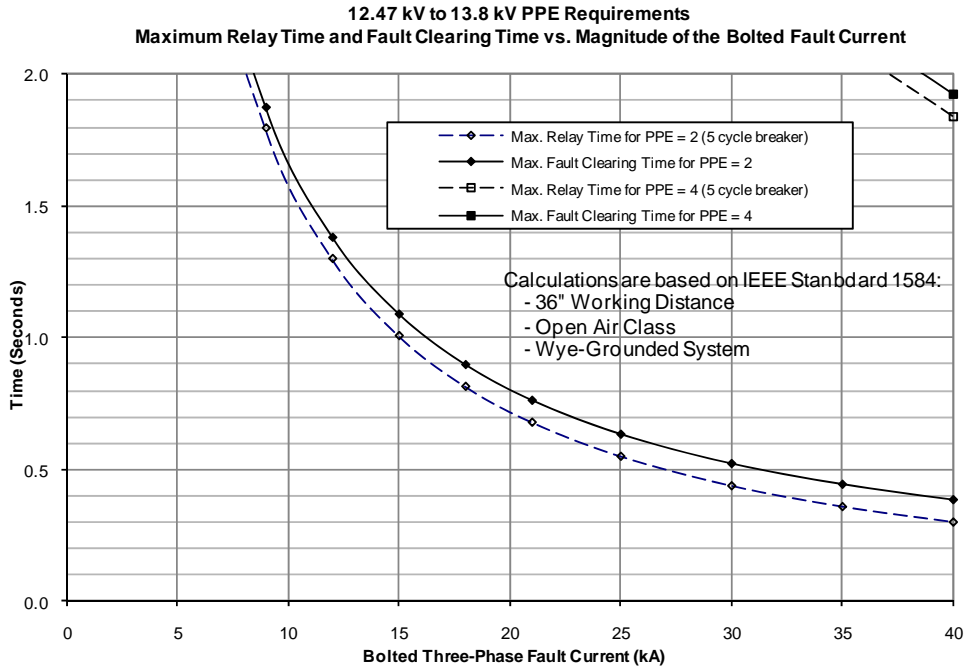

Figure 4

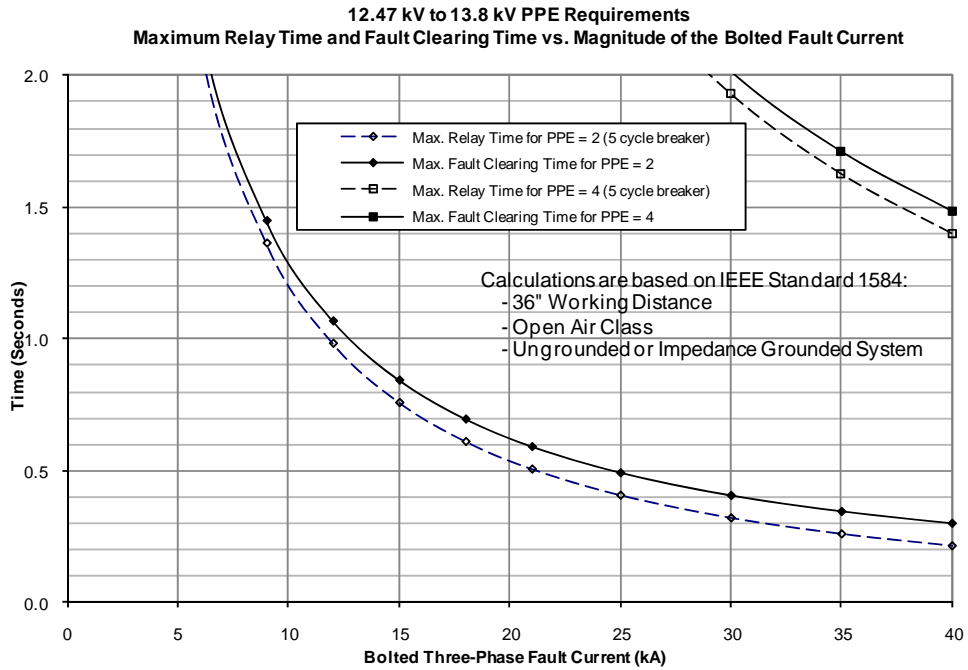

Figure 5

2.0 4.16 KV SYSTEMS

Using the equations given in IEEE 1584, curves are given which define the maximum clearing time for a given bolted (or maximum) fault current that would correspond to a PPE level of 2 or 4 for 4.16 kV systems. A working distance of 24" is used in Figures 6 and 7 to illustrate the calculated limits for metal enclosed switchgear for solidly grounded and impedance grounded systems respectively.

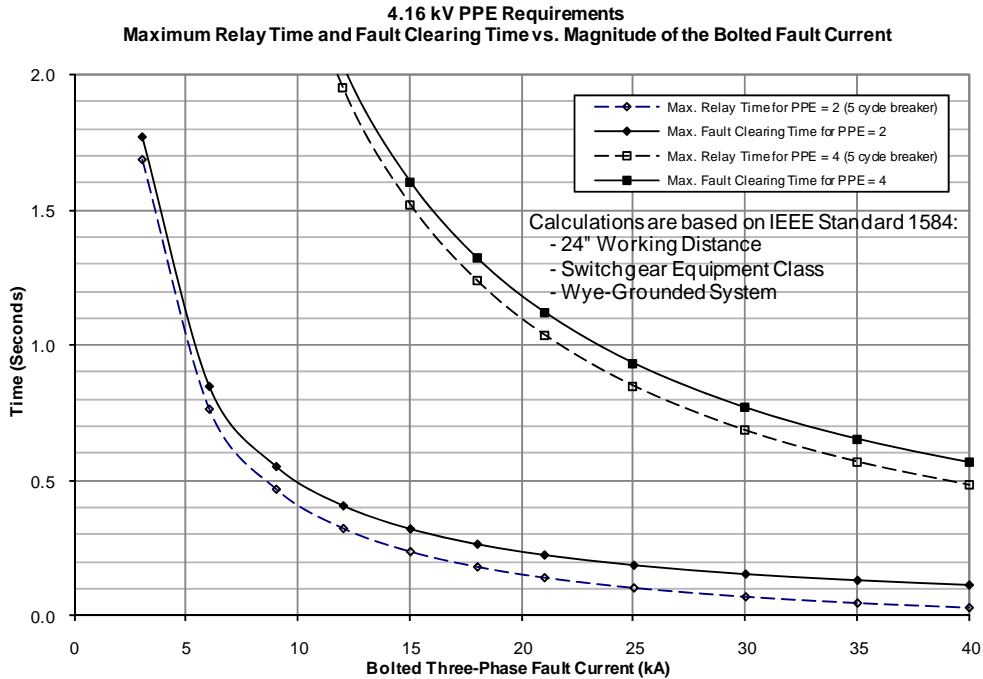

Figure 6

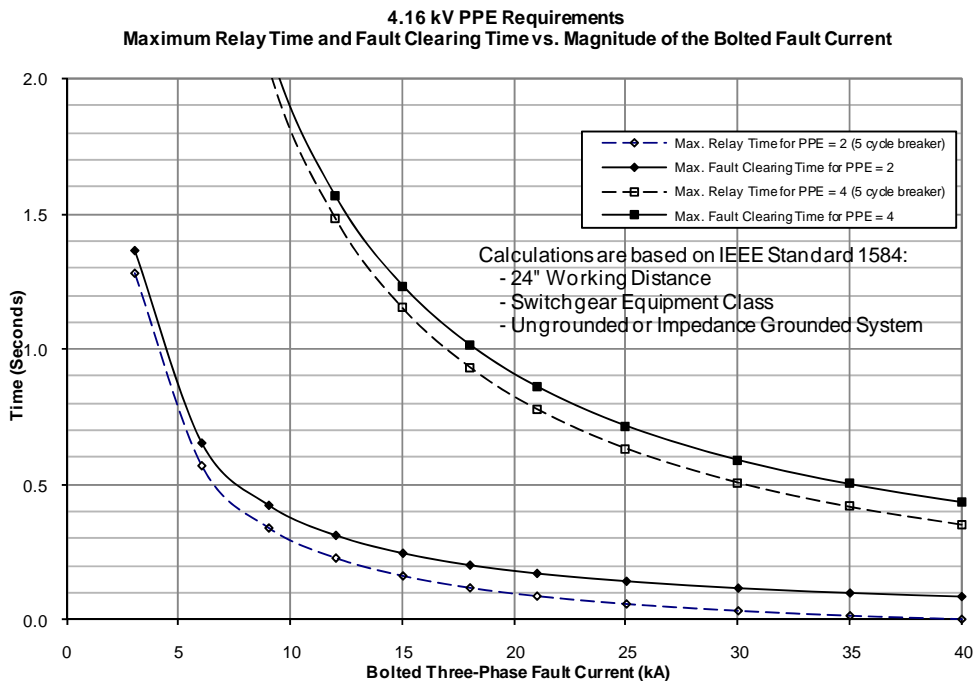

Figure 7

Figure 8 illustrates the calculated limits for a working distance of 36" for impedance grounded systems.

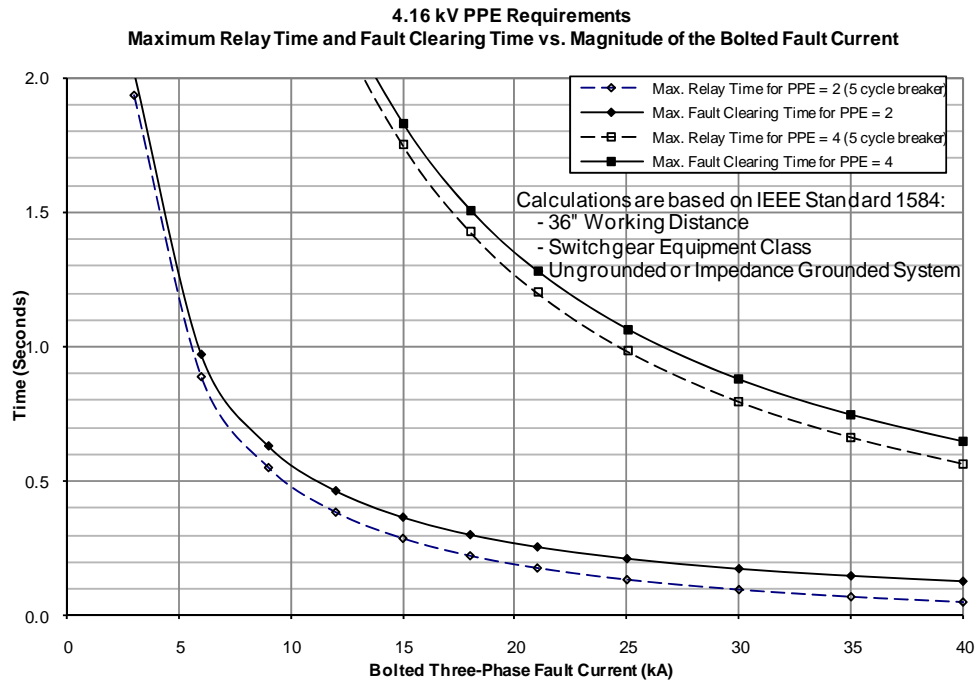

Figure 8

3.0 600 VOLT SYSTEMS

Using the equations given in IEEE 1584, curves are given which define the maximum clearing time for a given bolted (or maximum) fault current that would correspond to a PPE level of 2 or 4 for 600 volt systems. A working distance of 18" is used in Figures 9 and 10 to illustrate the calculated limits for metal enclosed switchgear for solidly grounded and impedance grounded systems, respectively.

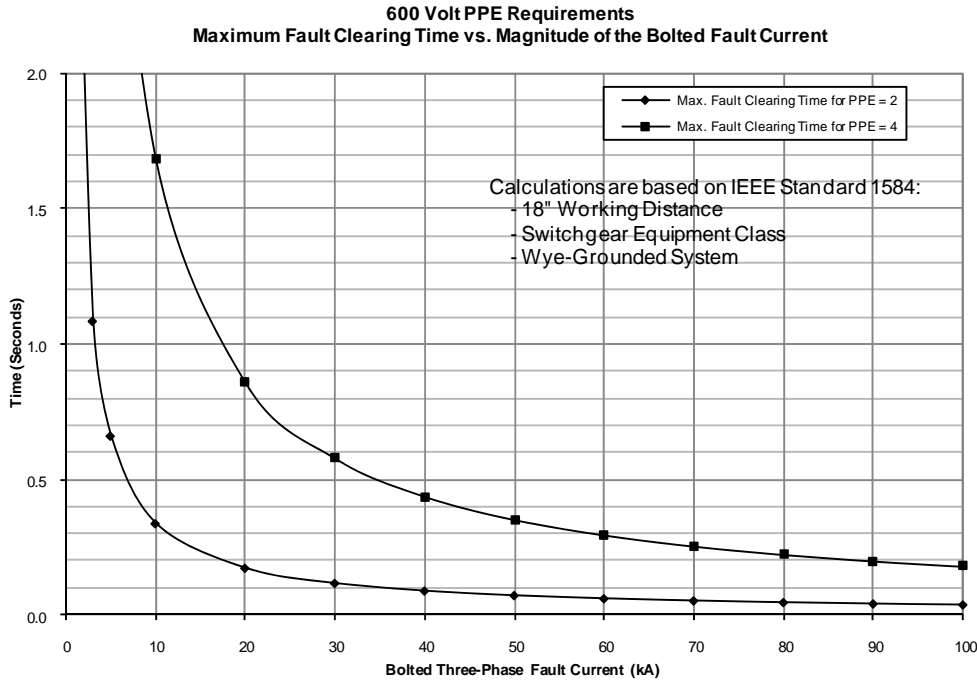

Figure 9

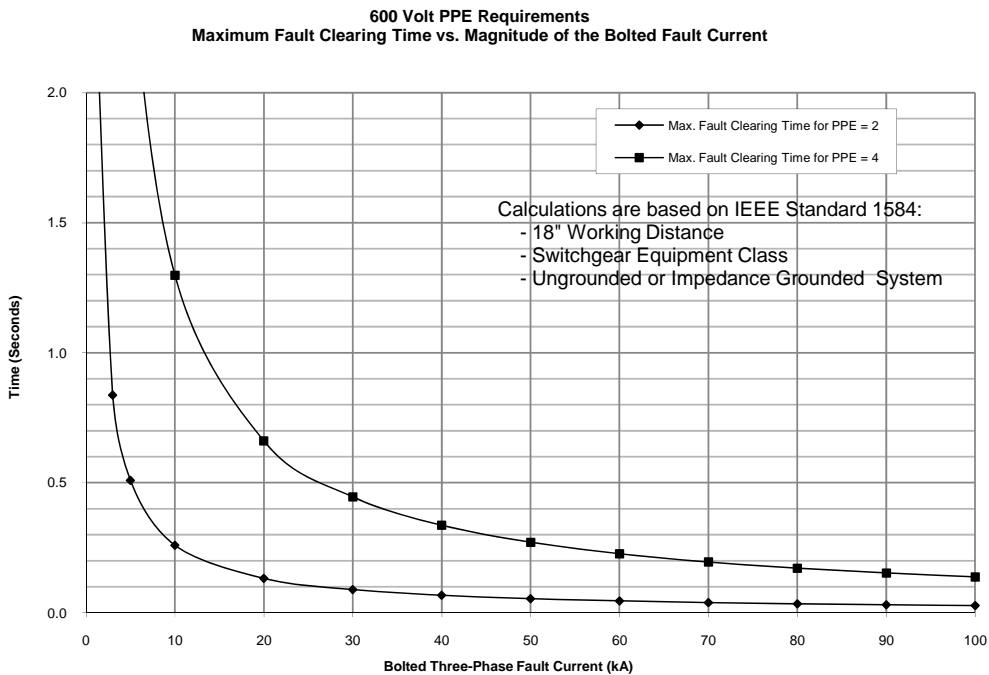

Figure 10

4.0 480 VOLT SYSTEMS

Using the equations given in IEEE 1584, curves are given which define the maximum clearing time for a given bolted (or maximum) fault current that would correspond to a PPE level of 2 or 4 for 480 volt systems. A working distance of 18" is used in Figures 11 and 12 to illustrate the calculated limits for metal enclosed switchgear for solidly grounded systems.

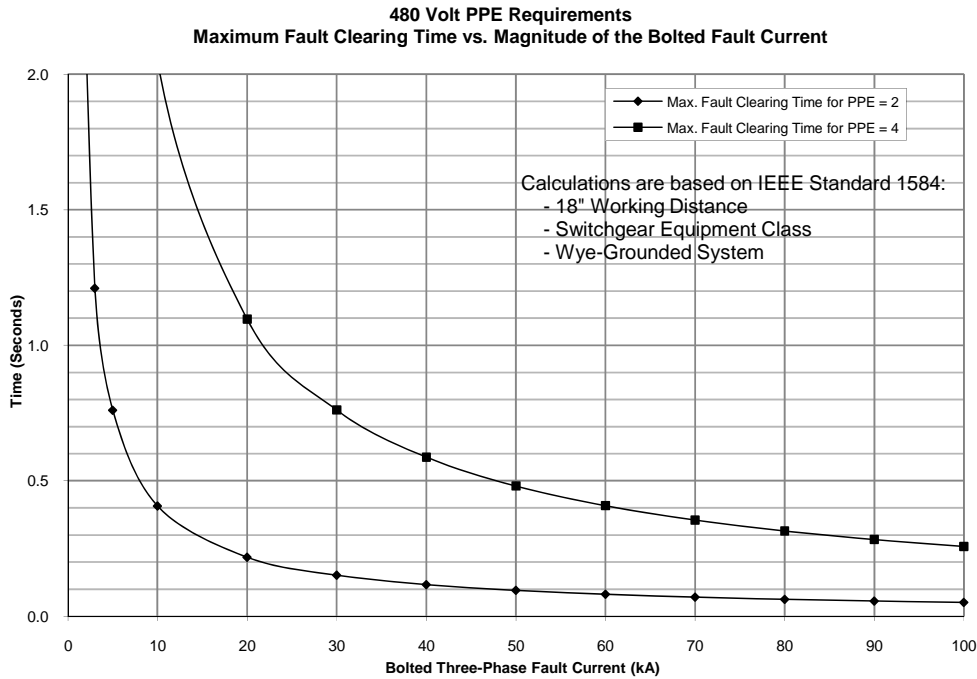

Figure 11

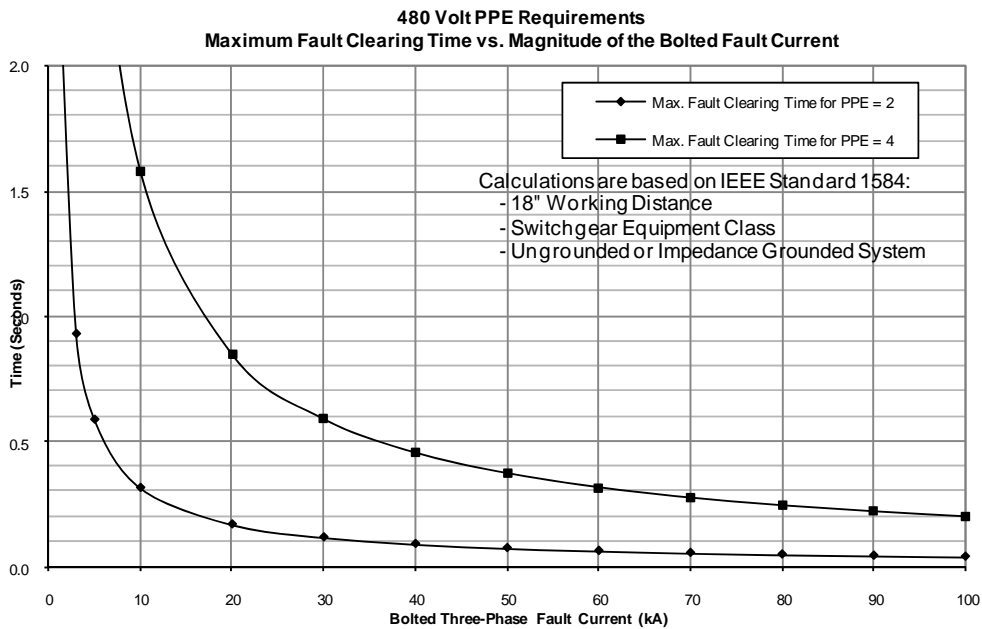

Figure 12

5.0 208 VOLT SYSTEMS

Using the equations given in IEEE 1584, curves are given which define the maximum clearing time for a given bolted (or maximum) fault current that would correspond to a PPE level of 2 or 4 for 208 volt systems. A working distance of 18" is used in Figures 15 and 16 to illustrate the calculated limits for metal enclosed switchgear for solidly grounded and impedance grounded systems, respectively.

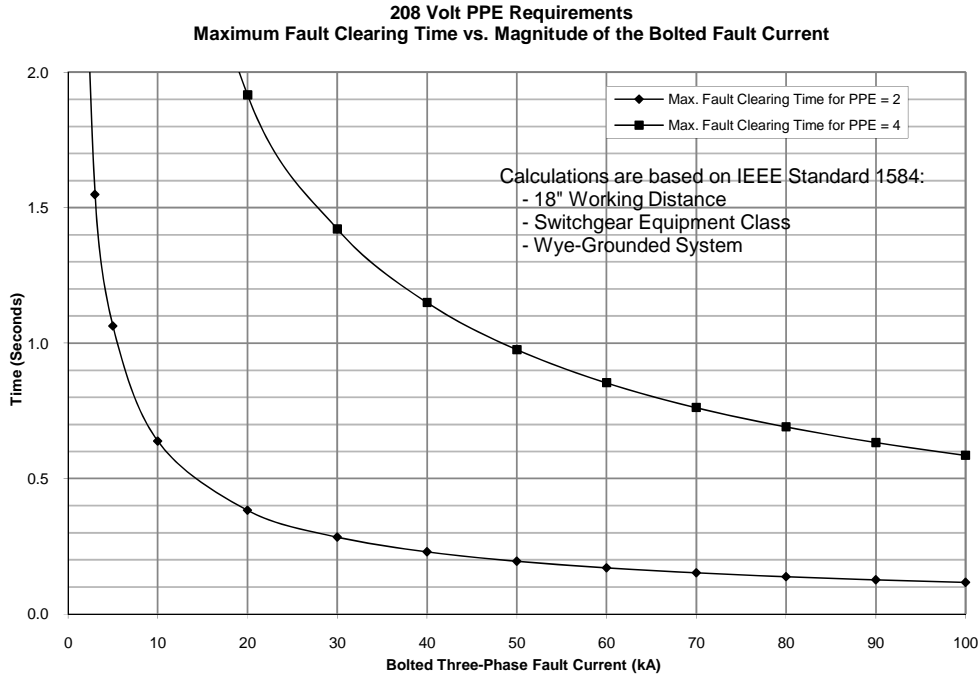

Figure 13

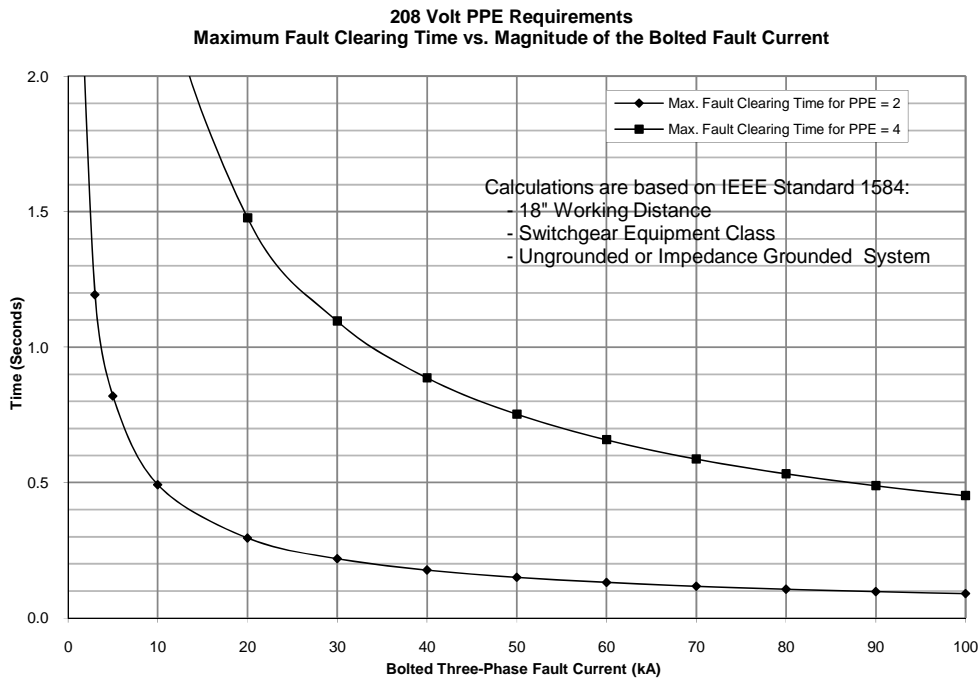

Figure 14

6.0 TYPICAL PPE LEVELS

Several examples are given here to illustrate typical PPE levels on industrial power systems due to different protection methods. There can be many variations in the parameters which can result in some variation of the PPE levels which are shown here.

Example 1

Figure 15 illustrates a portion of a typical industrial plant configuration, where the incoming voltage is in the range of 1 to 15 kV. Key observations and characteristics are noted as follows:

- The overcurrent protection on the medium voltage system is coordinated time overcurrent, but there is no differential protection on the main transformer or main bus.
- The medium voltage main breaker coordinates with the feeder breaker. The feeder breaker has an instantaneous trip, but the main breaker does not.
- A fuse on the primary of the transformer typically does not limit the PPE to ≤ 4 on the low voltage secondary (i.e. location 5) for transformers of ≥ 1500 kVA. For smaller transformers and/or tighter fusing, it is possible to achieve PPE = 4 at this location.
- A fuse on the main low voltage bus typically would not limit the PPE to ≤ 4 on the main bus (i.e. location 6).
- If the conductor length from location 7 to location 8 is quite long, the PPE level at location 8 can exceed PPE = 2.

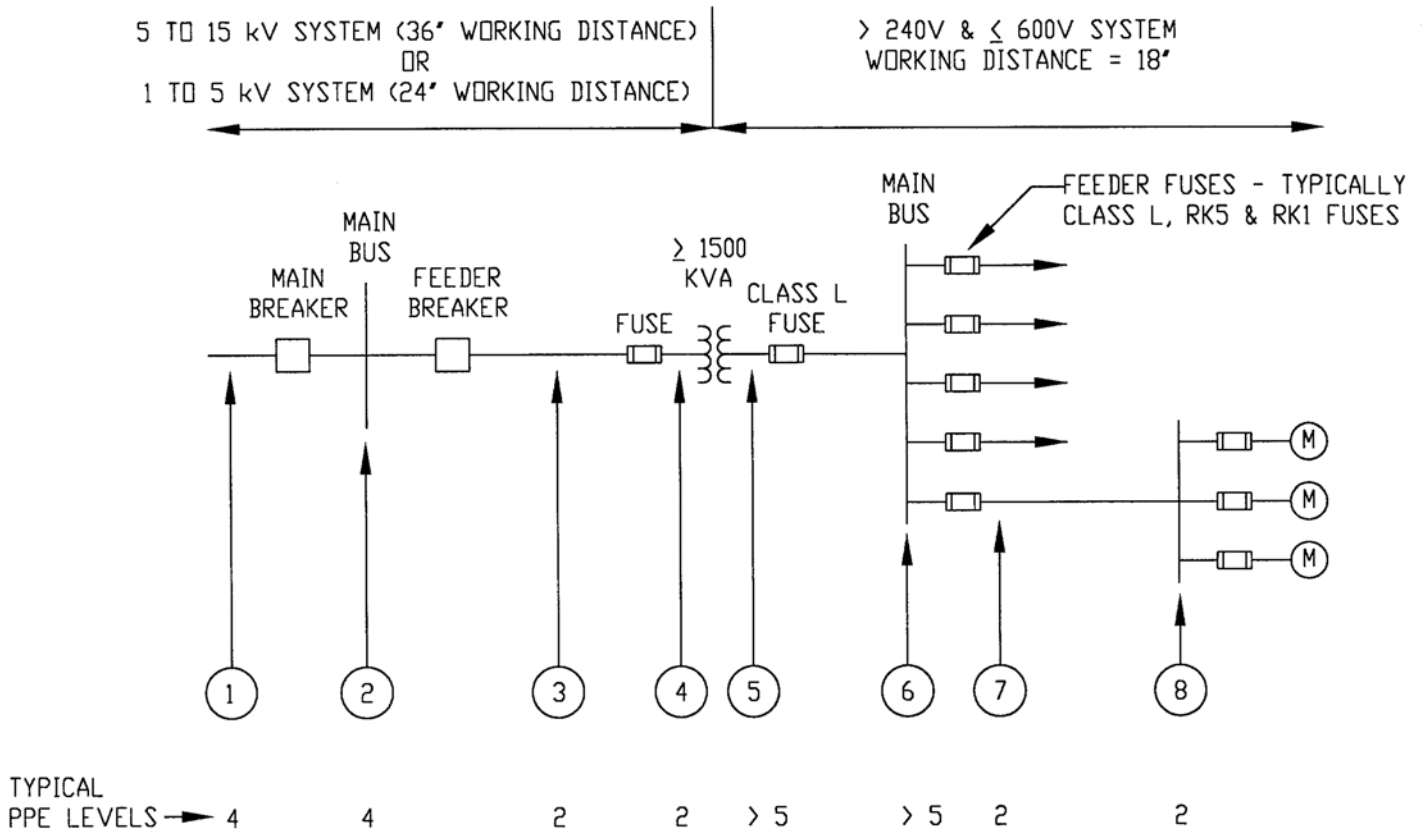

Figure 15

Example 2

Figure 16 illustrates a portion of a typical industrial plant configuration, where the incoming voltage is in the range of 1 to 15 kV. Compared to Example 1, low voltage breakers are illustrated instead of low voltage fuses. Key observations and characteristics are noted as follows:

- A main low voltage breaker can typically achieve PPE = 4 at location 6 if on the main breaker the short time pickup is ≤ 3 and the short time delay is < 0.4 seconds.
- At location 6, typically PPE = 2, if on the main breaker the instantaneous pickup is ≤ 3 ; however, this characteristic would not coordinate with the feeder breakers. This setting could be used as a temporary condition to allow some tasks to be done at this lower PPE level,
- At location 7, typically PPE = 2, if the feeder breaker is equipped with an instantaneous trip characteristic. If it does not have an instantaneous, typically PPE = 4.
- At location 8, typically PPE = 2, if the feeder breaker is equipped with an instantaneous trip characteristic. If it does not have an instantaneous and location 8 is relatively close to location 7, typically PPE = 4.

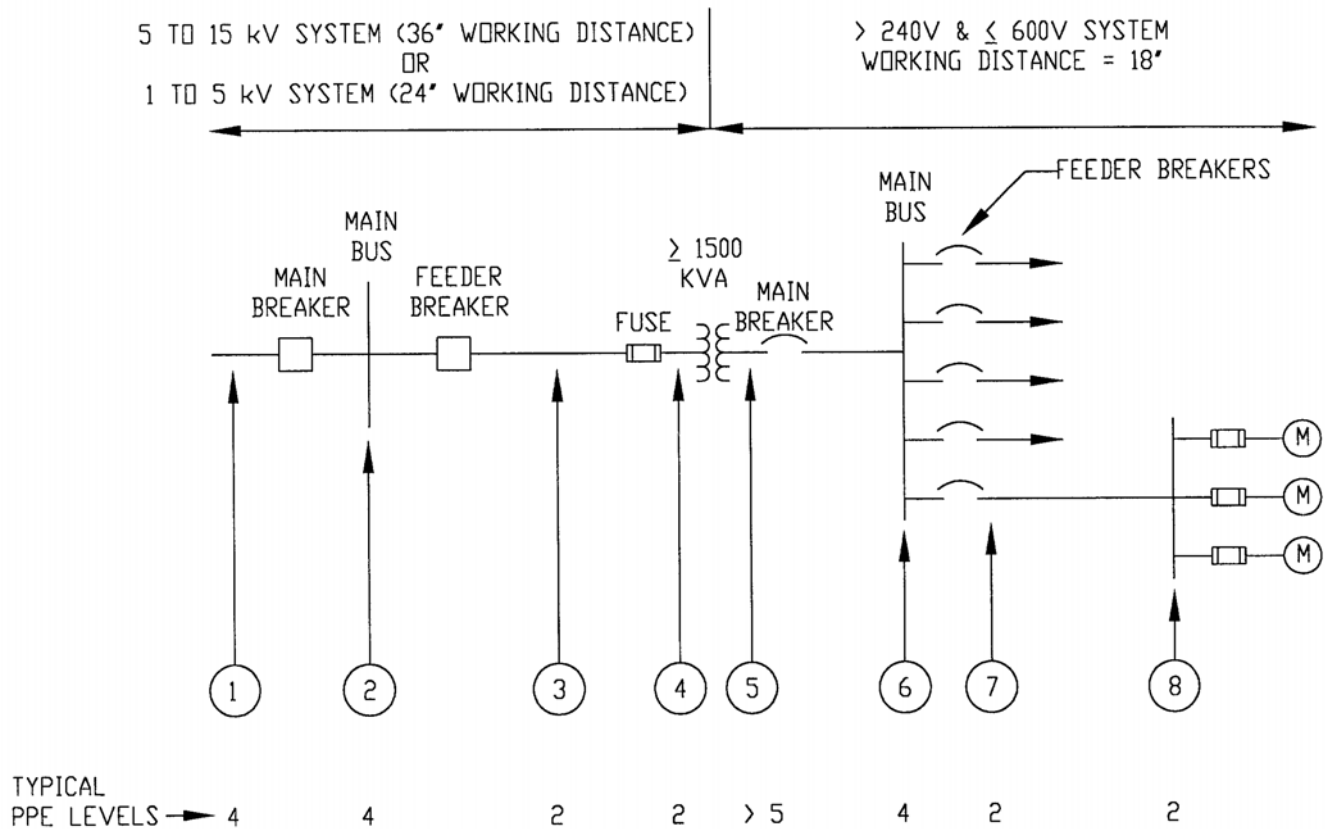

Figure 16

Example 3

Figure 17 illustrates a portion of a typical industrial plant configuration, where the incoming voltage is in the range of 1 to 15 kV. Compared to Example 2, differential protection is added to the medium voltage main transformer and the main bus. Key observations and characteristics are noted as follows:

- The faster differential protection, typically results in a PPE = 2 at locations 1 and 2.

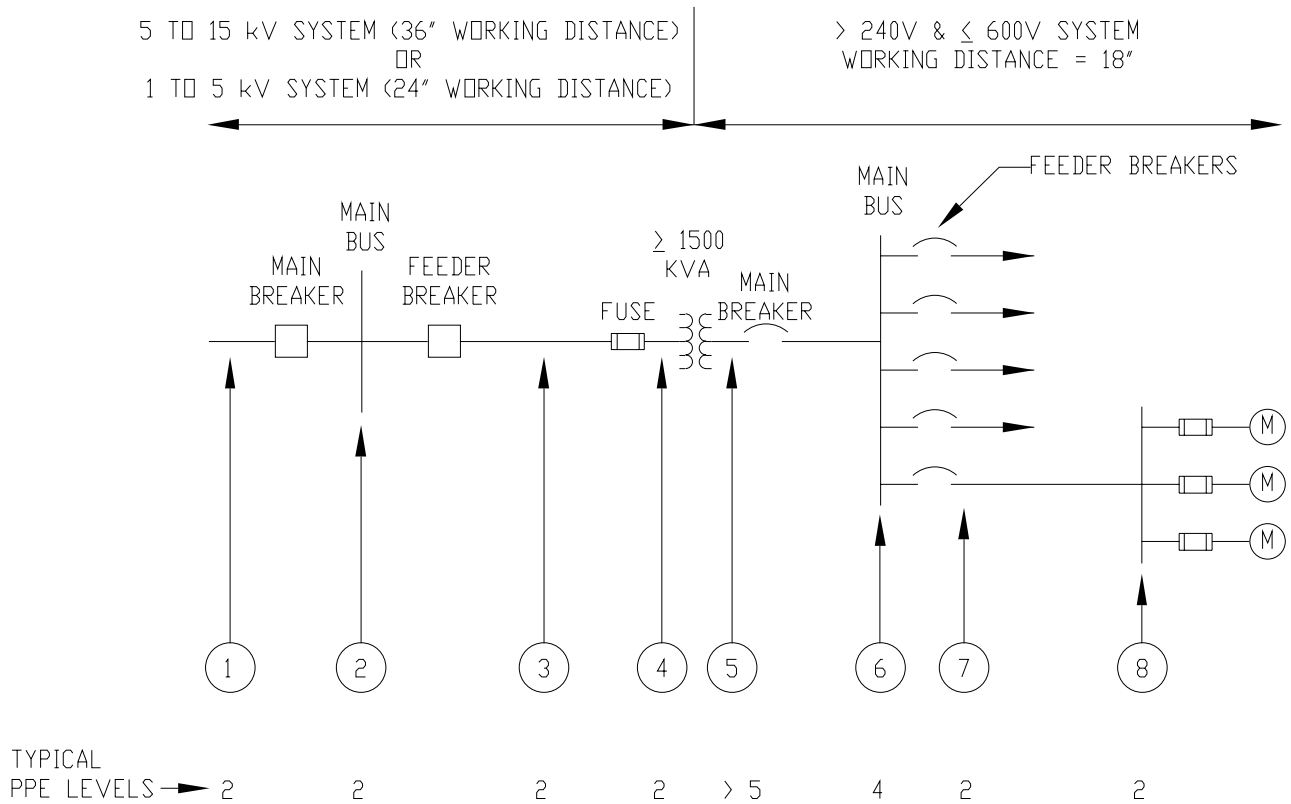

Figure 17

Example 4

Figure 18 illustrates a portion of a typical industrial plant configuration, where the incoming voltage is in the range of 1 to 15 kV. Compared to Example 3, a digital relay is used in the feeder breaker that has a definite time characteristic with a delay of 0.3 to 0.5 seconds that would result in the breaker tripping for a fault on the low voltage side of the transformer. Key observations and characteristics are noted as follows:

- The faster feeder relay typically results in a PPE = 4 at location 5. However, if multiple transformers are fed from the same medium voltage feeder breaker, power would be lost for all of these transformers for a three-phase secondary fault on one of the transformers.

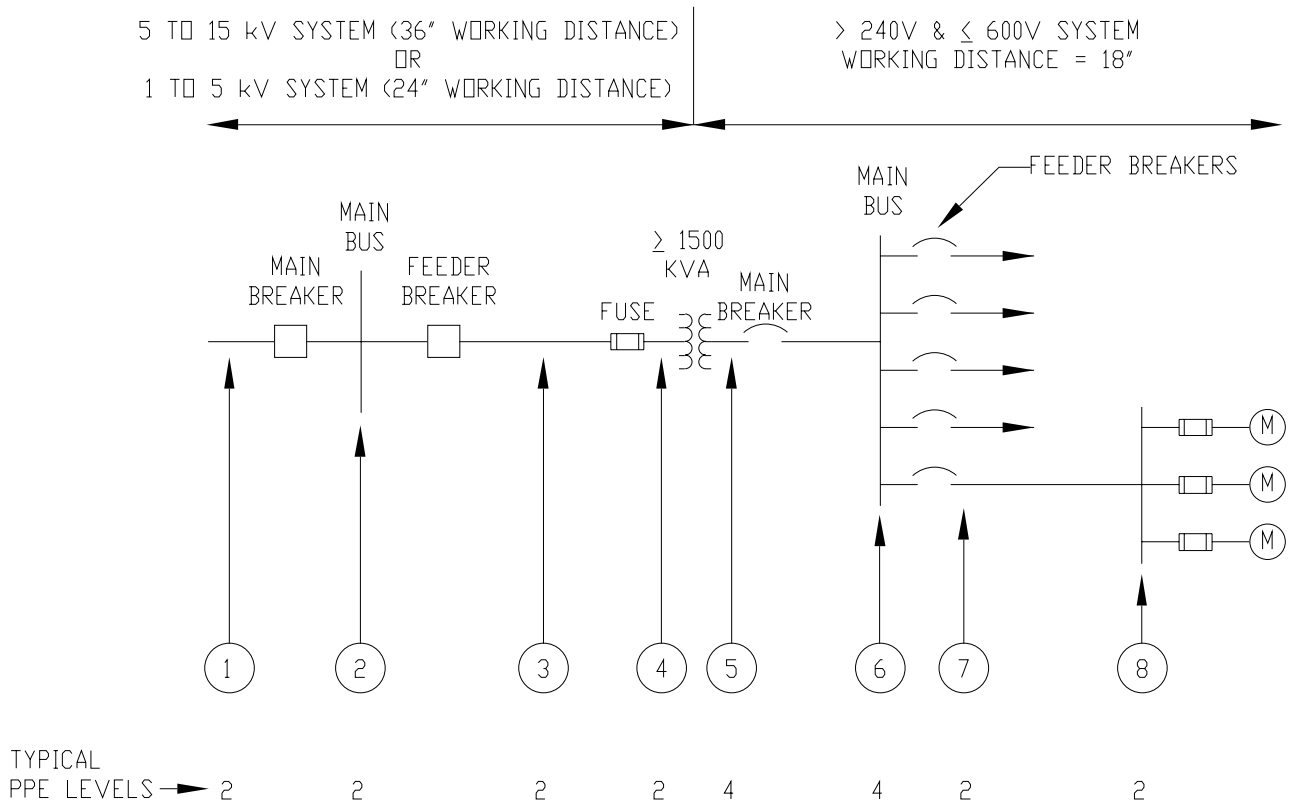

Figure 18